

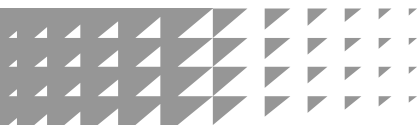

PROFESSIONAL

# PROFESSIONAL DIGITAL SPEAKER PROCESSOR



## Owner's Manual

### DIGITAL SYSTEM PROCESSOR

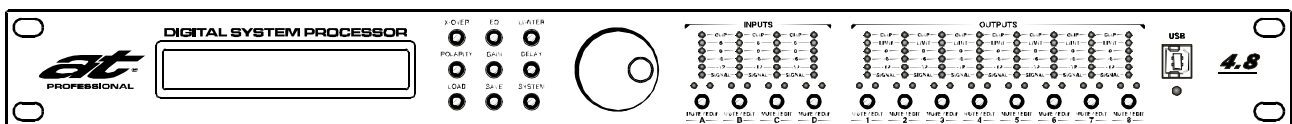
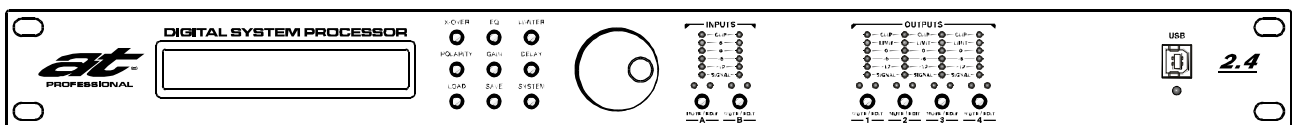

Before attempting to connect, operate or adjust this product, please read these instructions completely



# PROFESSIONAL DIGITAL SPEAKER PROCESSOR

## User Guide

Thank you for selecting our products.  
Please read this manual carefully to get the most out of your new unit.

Caution: Do not let this unit touch the rain or get wet, to avoid the fire or electric shock.

## CONTENTS

<b>Front Panel Controls and Connectors</b> .....	1
<b>Rear Panel Controls and Connectors</b> .....	2
<b>Panel Operation</b> .....	3
Input parameter setting .....	3
Output parameter setting .....	4
System Parameter setting .....	7
<b>PC Software Operation</b> .....	9
A. Connection .....	10
B. Signal edit vision at input state .....	13
C. Signal edit vision at Output state .....	13
D. EQ edit vision at Input / Output state .....	14



An equilateral triangle enclosing a lightning flash/arrowhead symbol is intended to alert the user to the presence of un-insulated "dangerous voltage" within the product's enclosure which may be of sufficient magnitude to constitute a risk of electric shock.



An equilateral triangle enclosing an exclamation point is intended to alert the user to the presence of important operating and service instructions in the literature enclosed with this unit.

## IMPORTANT SAFETY INSTRUCTIONS

# IMPORTANT SAFETY INSTRUCTIONS

**WARNING** - When using electric products, basic precautions should always be followed, including the following:

1. Read all the instructions before using the product.
2. Do not use this product near water (e.g., near a bathtub, washbowl, kitchen sink, in a wet basement, near a swimming pool, etc.).
3. This product should be used only with a cart or stand that will keep it level and stable and prevent wobbling.
4. This product, in combination with headphones or speakers, may be capable of producing sound levels that could cause permanent hearing loss. Do not operate for a long period of time at a high volume level or at a level that is uncomfortable. If you experience any hearing loss or ringing in the ears, you should consult an audiologist.
5. The product should be located so that its location or position does not interfere with its proper ventilation.
6. The product should be located away from heat sources such as radiators, heat vents, or other devices (including amplifiers) that produce heat.
7. The product should be connected to a power supply only of the type described in the operating instructions or as marked on the product. Replace the fuse only with one of the specified type and size and with the correct rating.
8. The power-supply cord should: (1) be undamaged, (2) never share an outlet or extension cord with other devices so that the outlet's or extension cord's power rating is exceeded, or (3) be left plugged into the outlet when left unused for a long period of time.
9. Care should be taken so that objects do not fall into and liquids are not spilled through the enclosure's openings.
10. The product should be serviced by qualified service personnel when:
  - A. The power-supply cord or the plug has been damaged; or
  - B. Objects have fallen, or liquid has been spilled onto the product; or
  - C. The product has been exposed to rain; or
  - D. The product does not appear to operate normally or exhibits a marked change in performance; or
  - E. The product has been dropped, or the enclosure damaged.
11. Do not attempt to service the product beyond that described in the user-maintenance instructions. All other servicing should be referred to qualified service personnel.

### IMPORTANT SAFETY INSTRUCTIONS

This product may be equipped with a polarized line plug (one blade wider than the other). This is a safety feature. If you are unable to insert the plug into the outlet, contact an electrician to replace your obsolete outlet. Do not defeat the safety purpose of the plug. (For use in the U.S.A.)

**IMPORTANT:** THE WIRES IN THIS MAINS LEAD ARE COLORED IN ACCORDANCE WITH THE FOLLOWING CODE.

BLUE: NEUTRAL / BROWN: LIVE

As the colors of the wires in the mains lead of this apparatus may not correspond with the colored markings identifying the terminals in your plug proceed as follows: The wire which is colored BLUE must be connected to the terminal which is marked with the letter N or colored BLACK. The wire which is colored BROWN must be connected to the terminal which is marked with the letter L or colored RED. Under no circumstances must either of the above wires be connected to the ground terminal of a three-pin plug.

**(For use in Europe)**

# Front Panel Controls and Connectors

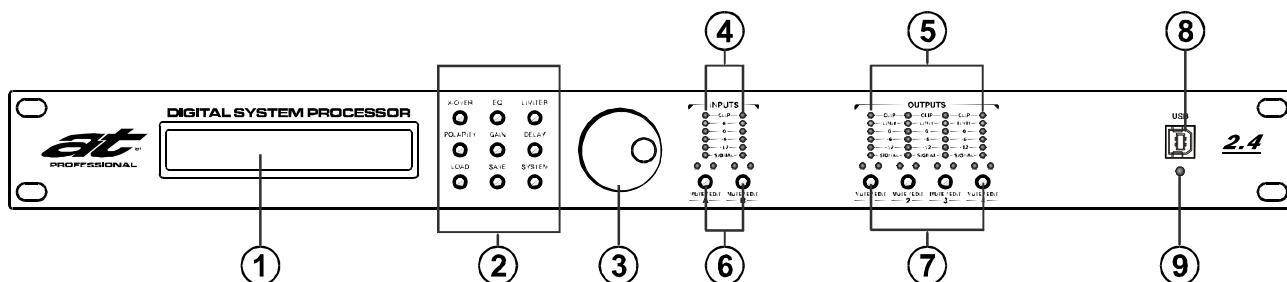

① LCD Display: Display the parameters and menu.

② Function select

X-OVER: Crossover setting (noneffective when edit the input channel, only can be used in editing the output channel)

EQ: EQ setting

LIMITER: Limit function setting (noneffective when edit the input channel, only can be used in editing the output channel)

POLARITY: Polarity selecting

GAIN: Gain and input channel selecting (noneffective when edit the input channel, only can be used in editing the output channel)

DELAY: Delay setting

SAVE: Save current program (include delete function)

SAVE: Save mode

SYSTEM: System menu

③ Coder (Enter/Setup) : Edit parameters, switch menu, including Enter function.

④ Input display lamp:

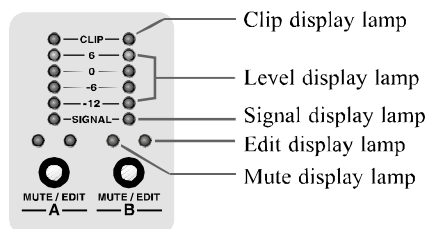

⑤ Output display lamp:

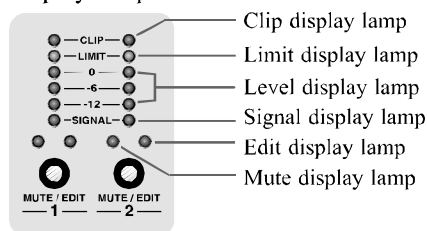

⑥ Input edit/Mute key: (Each Key control one red and one green LED indicator light)

⑦ Output edit/Mute key: (Each Key control one red and one green LED indicator light)

Note: Input and Output edit/Mute key, Press the key red LED lights up for Mute function. Holding down the key for three seconds or longer into Edit function, green LED lights up. Can edit selected channel parameters.

⑧ USB connectors: Connect with the PC in close quarters.

⑨ USB connector display lamp: Lights up when USB connected.

## Rear Panel Controls and Connectors

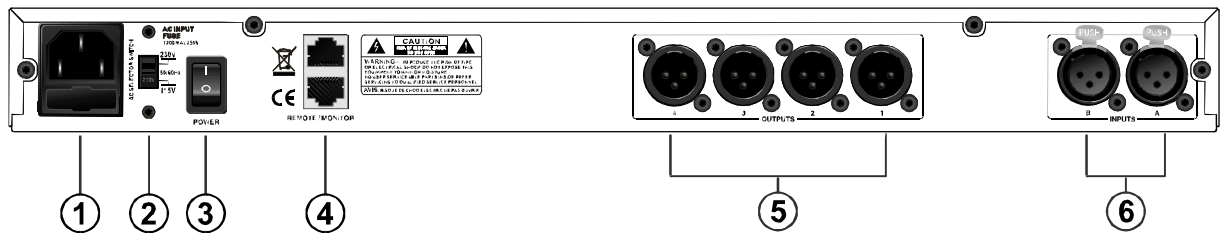

- ① Power Cord.
- ② AC power voltage selecting switch: Please check the local voltage before insert the power cord into an AC output. 115V(60Hz) or 230V(50Hz)
- ③ Power Switch.
- ④ RS-485 network connector, for connection to a computer or other digital speaker processor or other device in the network.
- ⑤ OUTPUT Connectors: These XLR-3-32 Balanced connectors output each channel analog audio signals.
- ⑥ INPUT Connectors: These XLR-3-31 Balanced connectors input each channel analog audio signals.

## Features

- \* Has multi inner function and high precision digital speaker processor.
- \* Use 64 bits floating point unit, made the operation precision more higher.
- \* Use 96KHz sampling frequency, one time higher than the similar products in the market. Sound more nicety, less distortion.
- \* Friendly design, all the function can adjust in the panel.
- \* PC long-distance control by use the attached software:  
short distance can be control by connecting through USB connector or RS-485 connector. Long-distance control through RS-485 connector. It can control maximum 250 pcs products, maximum distance 1000 meters. (difference according to environment).
- \* Can set program in PC through software and set relevant parameter.

# Panel Operation

## Input parameter setting:

Holding down the “IN A /IN B” key for three seconds or longer, Green display of the relevant channel lights up, and relevant channel into edit (each channel default setting “input mute”), short press function key into relevant parameter setting menu. Turn coder for parameter setting, short press coder switch / confirm relevant parameter.

### 1. Input Polarity setting:

**【Parameter】** Polarity, [+]: positive [-]: negative pole Each channel has unattached phase control.

**[[Example]]** 1. Holding A channel "input edit/Mute" for 3 seconds until green display lights up, into editing of A channel.

2. Press “POLARITY” , display as below:

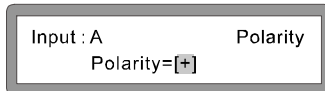

3. Turn coder, change the polarity.

### 2. Input Delay setting:

**【Parameter】** Delay, setting range 0~1000ms, Step pitch 21us @ 0~10ms, Step pitch 84us @10~20ms, Step pitch 0.5ms over 20ms. Each channel has unattached delay control.

**[[Example]]** 1. Holding A channel "input edit/Mute" for 3 seconds until green display lights up, into editing of A channel.

2. Press “DELAY” , display as below:

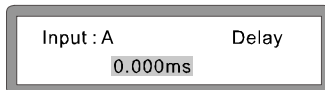

3. Turn coder clockwise, change the value.

### 3. Parameter EQ setting:

**【Parameter】** Input EQ, Each channel can set 6 parameter EQs (EQ1~EQ6) .

At Parameter state: Freq: 20Hz~20KHz Gain: -20dB~+20dB Bandwidth: 0.05/Oct~3/Oct

**[[Example]]** 1. Holding A channel "input edit/Mute" for 3 seconds until green display lights up, into editing of A channel.

2. Press “EQ” , display as below:



3. Turn coder clockwise, open Freq setting.

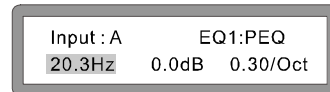

4. Press coder, confirm (Fred) setting, switch to next parameter(gain) setting, turn coder to change the parameter. (Turn coder clockwise, the value increase. Turn coder withershins, the value decreases.)

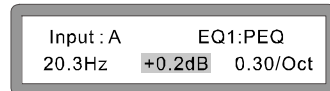

5. Press coder, confirm ( Gain ) setting, switch to next parameter( Bandwidth ) setting, turn coder to change the parameter.(Turn coder clockwise, the value increase. Turn coder withershins, the value decreases.)

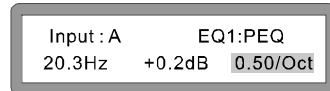

6. Press "EQ" key again, confirm (EQ1) setting, switch to next parameter (EQ2) setting, turn coder to change the parameter.

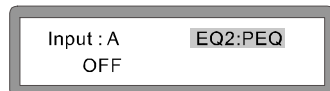

※ Short press "EQ" key can switch between EQ1~EQ6, Press each channel “Edit/ Mute” key for about 3 seconds, can switch between each channel.

# Panel Operation

## Output parameter setting:

Holding down the “OUT1~OUT4” key for three seconds or longer into parameter setting menu. Green display of the relevant channel lights up, and relevant channel into edit (each channel default setting “input mute” ), short press function key into relevant parameter setting menu. Turn coder for parameter setting, short press coder switch / confirm relevant parameter.

### 1. Output Gain setting:

【Parameter】 Gain, Setting range: -12.0dB~+12.0dB, Step pitch:  $\pm 0.1$ dB.

[[Example]] 1. Holding Out1 channel "Output edit/Mute" for 3 seconds until green display lights up, into editing of Out1 channel.

2. Press “GAIN” , display as below:

Output1	Gain
Input: A	Gain = 0.0dB

3. Turn coder, select the input channel which you need to open.

Output1	Gain
Input: A+B	Gain = 0.0dB

※ Each output can select difference input channel separate ( such as channel A or channel B or channel A+B or select non of them)

4. Press coder, confirm(input channel) setting, switch to next parameter(output gain) setting, turn coder to change the output gain parameter. (Turn coder clockwise, the value increase. Turn coder withershins, the value decreases.)

Output1	Gain
Input: A+B	Gain = +1.3dB

### 2. Limiter setting :

【Parameter】 Limiter, each channel has unattached limiter control.

A: THRESH: -20dBu~+20dBu

B: ATTACK: 0.3 ms~100ms

C: RELEASE: 2x、4x、6x、8x、16x、32x、

[[Example]] 1. Holding Out1 channel "Output edit/Mute" for 3 seconds until green display lights up, into editing of Out1 channel.

2. Press “LIMITER” , display as below:

Output1	Limit
THRESH: +20.0dBu	

Into THRESH edit setting, turn coder, change the thresh.

3. Press coder, confirm (THRESH) setting, switch to (ATTACK) setting, turn coder to change the value.

Output1	Limit
ATTACK: 100ms	

4. Press coder, confirm (ATTACK) setting, switch to (RELEASE) setting, turn coder to change the value.

Output1	Limit
RELEASE: 2x (200ms)	

※ Can set 2, 4, 6, 8, 16, 32 times as ATTACK.



# Panel Operation

### 3. Output Polarity setting:

【Parameter】 Polarity, [+]: positive [-]: negative pole. Each channel has unattached phase control.

- [[Example]] 1. Holding Out1 channel "Output edit/Mute" for 3 seconds until green display lights up, into editing of Out1 channel.  
2. Press "POLARITY" , display as below:

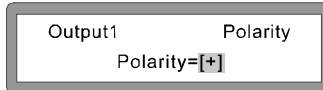

3. Turn coder, change the polarity.

### 4. Output Delay setting:

【Parameter】 Delay, setting range 0~1000ms, Step pitch 21us @ 0~10ms, Step pitch 84us @ 10~20ms, Step pitch 0.5ms over 20ms. Each channel has unattached delay control.

- [[Example]] 1. Holding Out1 channel "Output edit/Mute" for 3 seconds until green display lights up, into editing of Out1 channel.  
2. Press "DELAY" , display as below:

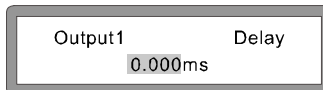

3. Turn coder clockwise, change the value.

### 5. X-OVER HPF & LPF setting:

【Parameter】 X-OVER, each channel has unattached HPF & LPF.

Highpass range: 20Hz~20KHz selectable filter type : Lin-Ril, Bessel, ButterW

Lowpass range: 20Hz~20KHz selectable slope: 12dB、18dB、24dB、48dB

- [[Example]] 1. Holding Out1 channel "Output edit/Mute" for 3 seconds until green display lights up, into editing of Out1 channel.  
2. Press "X-OVER" , display as below:

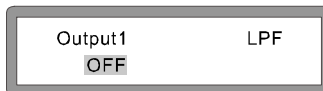

3. Turn coder withershins, turn on LPF setting.  
(Turn coder clockwise, the value increase. Turn coder withershins, the value decreases.)



4. Press coder, confirm the Frequency setting, switch to filter type selecting, turn coder to select filter type.

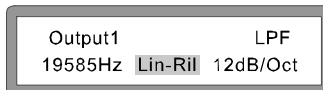

5. Press coder, confirm the filter type setting, switch to filter slope setting, turn coder to change slope value.



6. Press "X-OVER" key again, confirm LPF setting, switch to HPF setting.

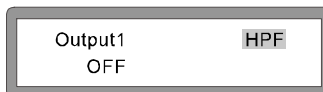

7. Turn coder clockwise, turn on HPF setting.  
( setting process same as LPF setting.)



# Panel Operation

## 6. EQ setting:

【Parameter】 Output EQ, Each channel can set 6 parameter EQs (EQ1~EQ6) .

**A:** At Parameter state: Freq: 20Hz~20KHz Gain: -20dB~+20dB Bandwidth: 0.05/Oct~3/Oct

**B:** At Lo\_Shelf、Hi-shelf state: Freq: 20Hz~20KHz Gain: -20dB~+20dB Slope: +6dB、+12dB

- [[Example]] 1. Holding Out1 channel "Output edit/Mute" for 3 seconds until green display lights up, into editing of Out1 channel.  
2. Press "EQ" , into "Parameter" state setting display as below:

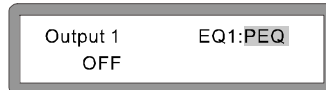

3. Turn coder clockwise, can switch to "Lo-Shelf" or "Hi-shelf" setting



4. Press coder, confirm select "Lo-Shelf", into parameter setting. Turn coder clockwise, turn on Fred setting.  
(Turn coder clockwise, the value increase. Turn coder withershins, the value decreases.)

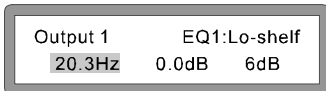

5. Press coder, confirm (Fred) setting, switch to next parameter(gain) setting, turn coder to change the parameter.  
(Turn coder clockwise, the value increase. Turn coder withershins, the value decreases.)

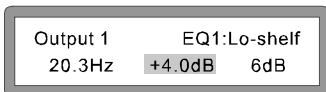

6. Press coder, confirm (Gain) setting, switch to next parameter(Slope) setting, turn coder to change the parameter.  
(Turn coder clockwise, the value increase. Turn coder withershins, the value decreases.)

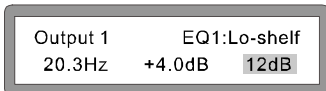

7. Press "EQ" key again, confirm (EQ1) setting, switch to next parameter (EQ2) setting.

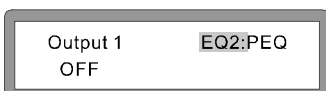

- ※ Short press "EQ" key can switch between EQ1~EQ6, Press each channel "Edit/ Mute" key for about 3 seconds, can switch between each channel.
- ※ ( "Parameter" or "Hi-shelf" setting process same as "Lo-Shelf" setting)

# Panel Operation

## System Parameter setting:

All the setted parameter can be saved in the memorizer for use the same mode in the future. At function selecting, short press function key into relevant parameter setting menu. Turn coder for parameter setting, short press coder switch / confirm relevant parameter.

### 1. Load setting:

【Parameter】 Load, Load saved mode.

[[Example]] 1. Press “LOAD” key, display as below:

A rectangular LCD display with a grey border. The text on the screen reads "Select and Load" on the top line and "1. 2x(2way+Sub)" on the bottom line.

2. Turn coder, select the wanted mode of loading. Press coder to confirm this loading mode, display as below:

A rectangular LCD display with a grey border. The text on the screen reads "Waiting" on the top line and "Loading....." on the bottom line.

A rectangular LCD display with a grey border. The text on the screen reads "Loading Successful" on the top line.

※ Loading mode completely.

### 2. Save setting: (include delete function)

【Parameter】 Save, save current mode, total can save 30 difference modes.

Delete, Delete saved program. (Holding the “Save” key for 3 seconds can delete the selected program.)

[[Example]] 1. Press “SAVE” key, display as below:

A rectangular LCD display with a grey border. The text on the screen reads "Select store Place" on the top line and "1." on the bottom line.

※ total can save 30 difference parameter setting.

2. Turn coder, select the wanted number to modify. Press coder, confirm into the selected number. display as below:

A rectangular LCD display with a grey border. The text on the screen reads "Input User Group Name" on the top line and "A" on the bottom line.

3. Now turn coder, modify the name of the save mode. such as: 2x(2way+Sub)

A rectangular LCD display with a grey border. The text on the screen reads "Input User Group Name" on the top line and "2x(2way+Sub)" on the bottom line.

※ Turn Coder, select the wanted letter, number or symbol. Press coder to confirm.

4. Holding the coder for about three seconds, confirm to save this mode, display as below:

A rectangular LCD display with a grey border. The text on the screen reads "Storing Successful" on the top line.

※ Save this mode completely.

[[Example]] 1、 Press “SAVE” key, turn coder, select the program intend to delete. Such as: 2x(2way+Sub)

A rectangular LCD display with a grey border. The text on the screen reads "Select store Place" on the top line and "1. 2x(2way+Sub)" on the bottom line.

# Panel Operation

2. Holding the "SAVE" key for 3 seconds, display as below:

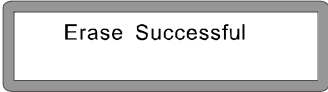

Erase Successful

※ It means the program has been deleted.

## 3. System setting:

【Parameter】 System. system menu.

※ Turn coder into relevant parameter setting menu, short press coder confirm the relevant parameter.

1).Device id setup ID (1~250)



< System Setup Menu >  
1. Device ID Setup

※Note: Each unit device one ID, when multi units connect together, the computer can choose difference ID for difference unit for setting.(Each unit device ID is 1 in factory )

2).Password setting



< System Setup Menu >  
2. Password

※Note: User can setup the password for each unit, provide the unit not be modify for the nonlicet user. (Please remember the password, if forgot the password please contact the supplier.)

3).Power on setup

Note: Power on setting can choose All Mute or keep in last state.

1. All Mute
2. Keep in last state.

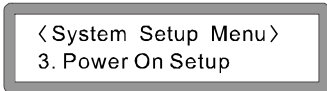

< System Setup Menu >  
3. Power On Setup

4).Backlight setup LCD backlight setting

Note: Thihs function can setup the LCD back light long-time. User can select keep on for long-light or turn off itself after 10 seconds sparetime. It can enlarge the LCD life.

1. Keep On: Keep on for long-time
2. 10s: turn off itself after 10 seconds sparetime



< System Setup Menu >  
4. Backlight Setup

5).Current Program

Note: Display current using program.



< System Setup Menu >  
5. Current Program

6).System information

Note: Display the system version.



< System Setup Menu >  
6. System Information

# PC Software Operation

**DIGITAL SYSTEM PROCESSOR** use advanced Long-distance control technology, it can set all the function and control by connection software. It has strong function, steady quality. Short distance can be control by connecting through USB connector or RS - 485 connector. Long -distance control through RS - 485 connector. It can controls maximum 250 pcs products.

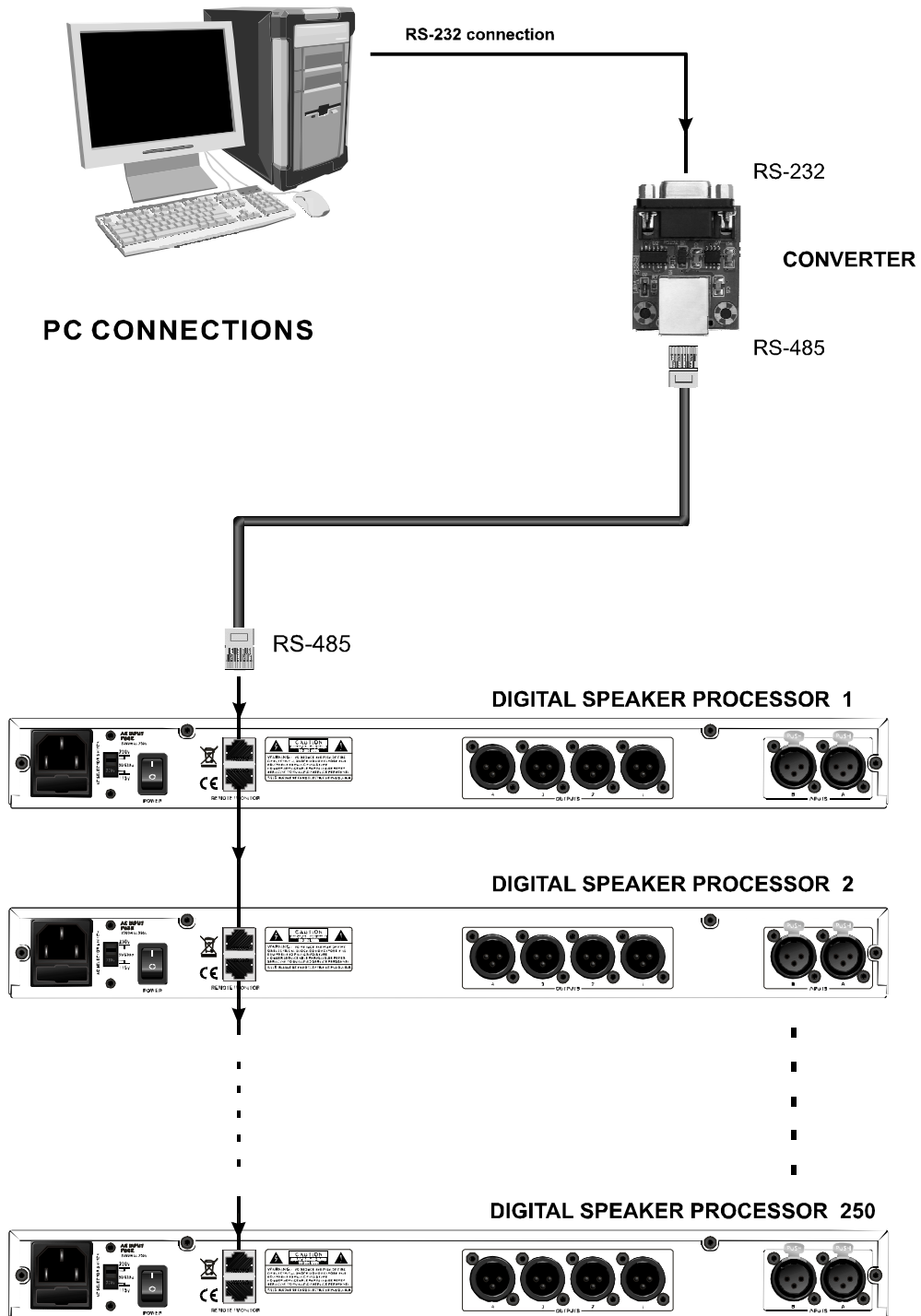

( Each speaker processor connected into this systems should be set up different ID. )

# PC Software Operation

Soft Vision:

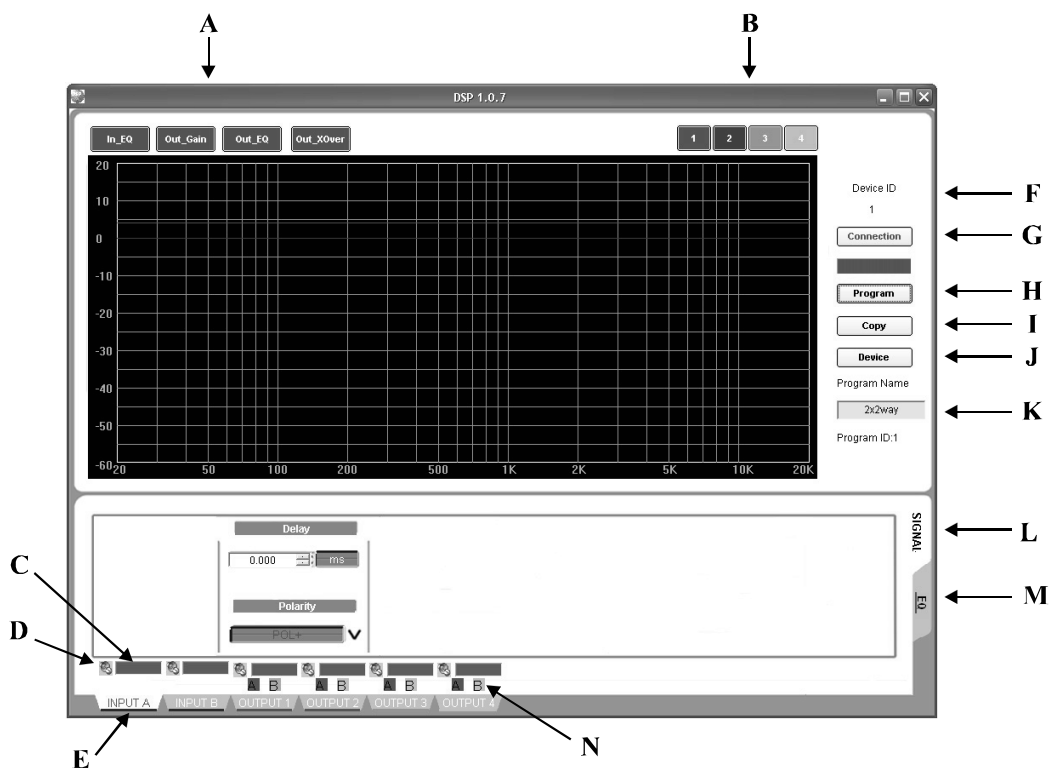

- A. Display Option
- B. Select display channel
- C. Signal Display
- D. Mute ON(OFF)
- E. Channel select switching
- F. Connected products ID
- G. Connection
- H. Save /Read program
- I. Copy
- J. Products selection
- K. Current using program and series number
- L. Signal edit
- M. EQ edit
- N. Input channel selection

**A. Connection:** ( Please confirm to use the connection line connect the computer and product. First connection need to install the driver, please use the attached CD )

**Connection** Connect state selection, after selected, display as below:

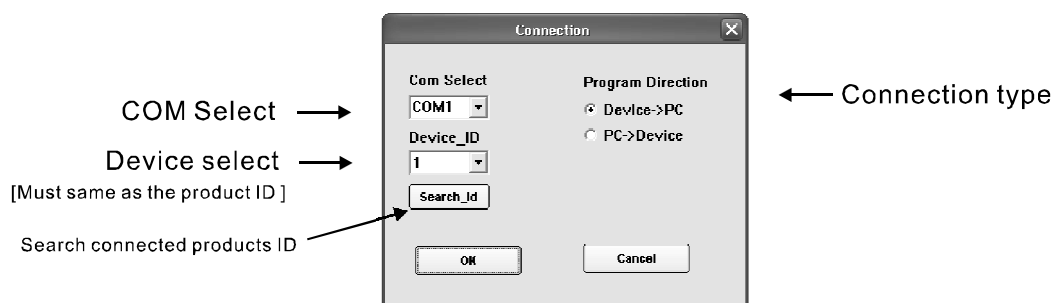

# PC Software Operation

**Program** Click into below page.

Select to use PC or any mode process of the product. Also can select the save type.

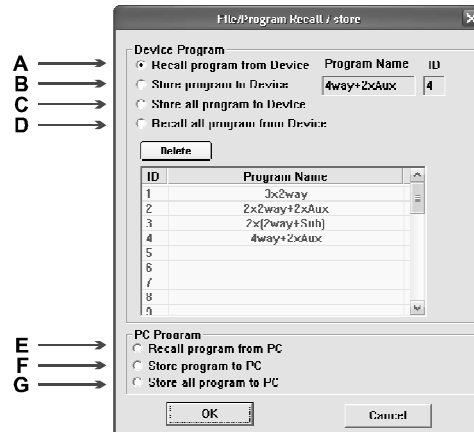

## 1. When editing one program:

- A. Recall program from Device.
  - B. Store program to Device.
  - E. Recall program from PC.
  - F. Store program to PC.
- ( Default save in the "Music File" of the root directory)

※ When editing one program, saved file as DIA format.

## 2. When editing all programs:

For easy to setting mutli products with same parameter, please operate according to below steps:

- 1) D. Recall all program from Device: read all the data (30 groups) at the same time.
- 2) G. Store all program to PC: Save all the data (30 groups) into the PC.
- 3) C. Store all program to Device: open all the saved files (30 groups) and load into the products.

※ When editing all programs, saved file as DAT format.

## 3. When delete one program:

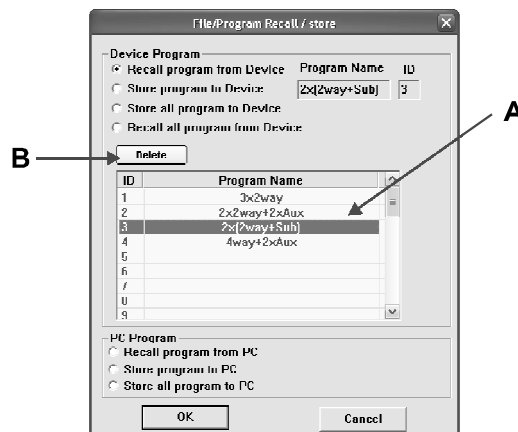

- A. Select one program.
- B. Click  , delete the selected program.

# PC Software Operation

**Copy**

Channel copy mode select:

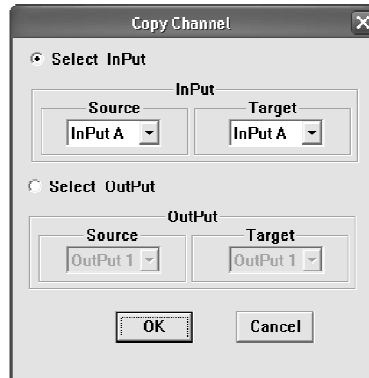

Can set two channels directly as same parameter.





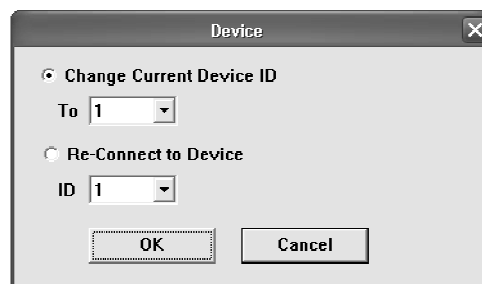

**Device**

Device: Click into below vision.



1. Change Current Device ID.
2. Re-Connect to Device.

Below is normal setting content:

-  Mute off, channel normal use.       Mute on, channel in mute.
-  Channel in gray colour means the channel doesn't be selected.
-  Click channel can switch the selection state, selected channel display relevant colour.
-  White background display the editing channel.
-  Grey background display non-editing channel.



# PC Software Operation

## B. Signal edit vision at input state:

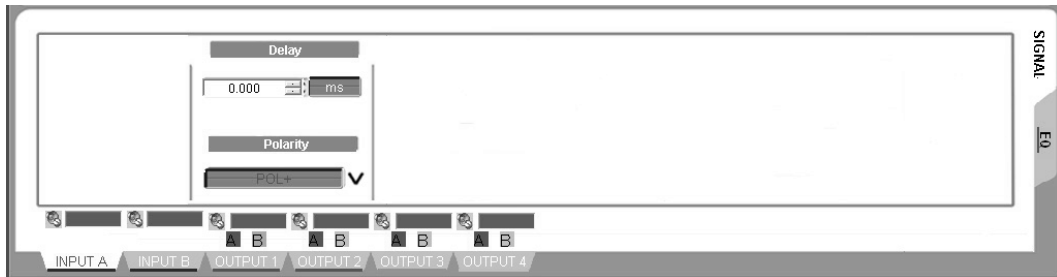

### 1. Input Delay setting:

Click **ms** can select delay unit(ms /Ft /M)

【Parameter】 Delay, Setting range: 0~1000ms, Each channel has unattached delay control.

### 2. Input Polarity setting:

Click **POL+** can select +/- polarity.

【Parameter】 Polarity, [+]: positive [-]: negative pole. Each channel has unattached phase control.

## C. Signal edit vision at Output state:

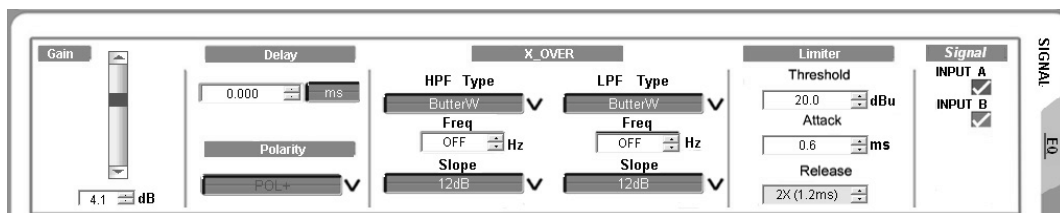

### 1. Output Gain setting:

【Parameter】 Gain, setting range: -12.0dB~+12.0dB, Step pitch:  $\pm 0.1$ dB。

### 2. Output Delay setting:

Click **ms** can select delay unit(ms /Ft /M)

【Parameter】 Delay, Setting range: 0~1000ms, Each channel has unattached delay control.

### 3. Output Polarity setting:

Click **POL+** can select +/- polarity.

【Parameter】 Polarity, [+]: positive [-]: negative pole. Each channel has unattached phase control.

### 4. X-OVER setting: (Dragging the X-over curve(H/L) by mouse can set the relevant parameter.)

【Parameter】 HPF & LPF, each channel has unattached HPF & LPF

Selecting range: 20Hz~20KHz selectable filter type : Lin-Ril, Bessel, ButterW

selectable slope: 12dB, 18dB, 24dB, 48dB



Click to switch the filter type



Click to switch the slope.

# PC Software Operation

## 5. Limiter setting:

【Parameter】 Limiter, each channel has unattached limiter control.

**A:** Threshold: -20dBu~+20dBu

**B:** Attack: 0.3 ms~100ms

**C:** Release: 2x、4x、6x、8x、16x、32x、

## 6. Select input channel:

【Parameter】 Sing, Each output can select difference input channel signal. (Free compounding)

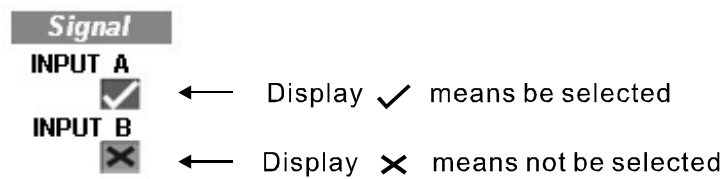

## D. EQ edit vision at Input / Output state:

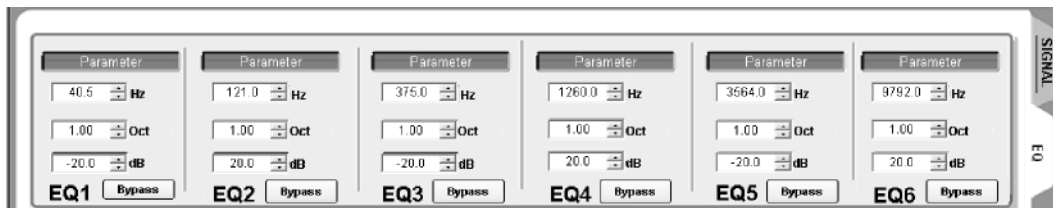

### 1. Parameter EQ setting: (Dragging the EQ number icon(1\2\3\4\5\6) by mouse can set the relevant parameter.)

【Parameter】 Input Eq, Each input channel can set 6 parameter EQs (EQ1~EQ6)。

At Parameter state: Freq: 20Hz~20KHz Gain: -20dB~+20dB Band width: 0.05/Oct~3/Oct

【Parameter】 Output Eq, Each output channel can set 6 parameter EQs (EQ1~EQ6)。

**A:** At Parameter state: Freq: 20Hz~20KHz Gain: -20dB~+20dB Bandwidth: 0.05/Oct~3/Oct

**B:** At Lo\_Shelf、Hi-shelf state: Freq: 20Hz~20KHz Gain: -20dB~+20dB Slope: +6dB、+12dB

**Parameter** Click can switch EQ mode (Invalidation at input state)

**Bypass** Black letter display available EQ.

**Bypass** Red Letter display bypass EQ.

## PC Software Operation

Select curve content. Blue background is selected, gray background is not be selected.



Select display channel curve, grey are not be selected:



Curve display vision:

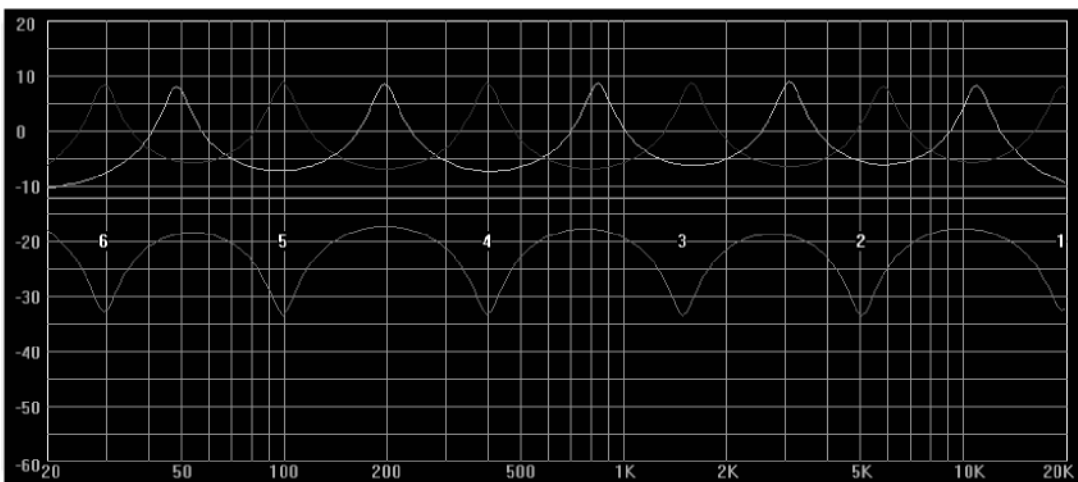

※ Dragging the EQ number icon (1\2\3\4\5\6) by mouse can set the relevant parameter.

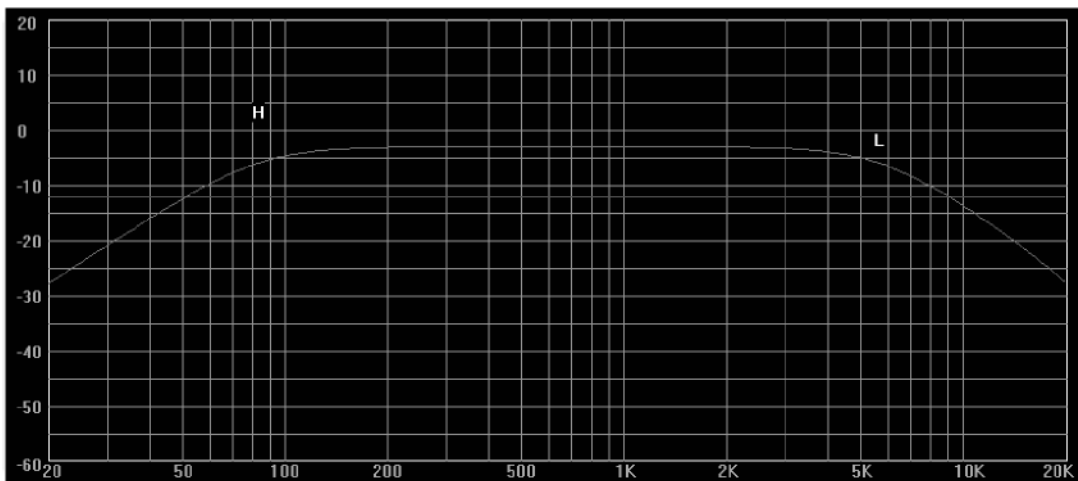

※ Dragging the X-over curve(H\L) by mouse can set the relevant parameter.

